

1595: Cuvette

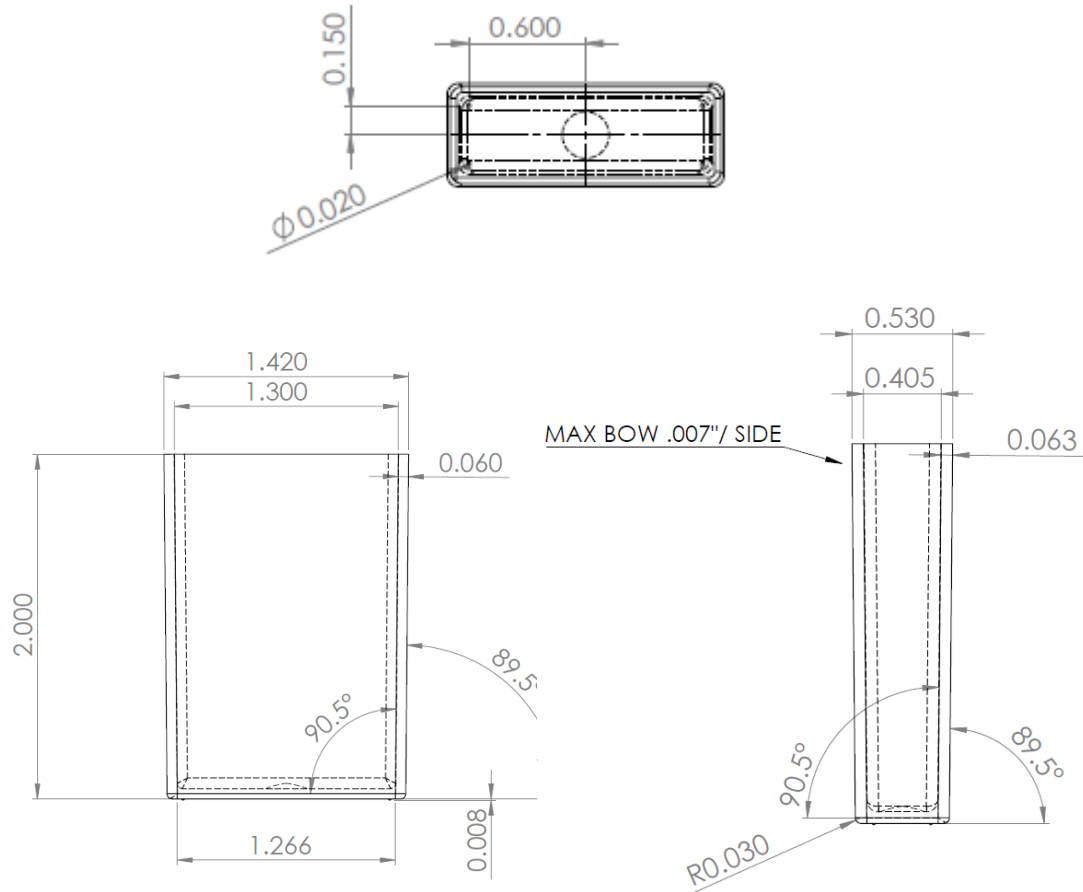

Cuvette

Fabricated of Makrolon, (Robust, lightweight and heat-resistant polycarbonate resin) with a glass-like transparency and a high dimensional stability. **(Optical type finish 5 sides)**

It is used in various products for medical, automotive, lighting, electronics and other industries.

Cuvettes are small tube like container with straight sides circular or square cross section and sealed at one end.

They are designed to hold samples for spectroscopic measurements, where a beam of light is passed through the sample within the cuvette. This measurement is done with aspectrophotometer.

Hudson Valley Plastics 85 Charles Colman BLVD Pawling NY 12564 P: 845-855-1201 hudsonvalleyplastics.com
Manufacturer reserves the right to make design and dimension changes without notice. Drawings are not to scale.

SPK.1595.06-28-24.R1